

ITEM NO.	QTY.	INV. NO.	DESCRIPTION	MATERIAL	DRAWING
1	1	24.4619PH	SEAT .56HP CHK VLV PHARMA	17-4 PH	B-13001
2	1	24.4204	GLAND .56 MP CHECK VALVE	316 SS	B-12999
3	1	24.4630	O-RING, #011 UHMWPE	UHMWPE	ND
4	1	24.4912PH	BALL .38 WC GRADE 25V PHARMA	TUNGSTEN CARBIDE	ND
5	1	24.4402PH	SPG .56HP CHK VLV 316SS PHARMA	316 SS	A-11516
6	1	24.4315PH	RETAINER SPG .56HP CHK VLV PHARMA	316 SS	B-11092
7	1	24.4106PH	BODY CHK VLV .56HP PHARMA	17-4 PH	B-13000

REVISIONS						
REV.	ZONE	ECN NO.	DESCRIPTION	DRAWN BY	APPROVED BY	DATE
A	-	-	RELEASED FOR MANUFACTURE	AY	JR	9/24/07
B	-	611	REVISED PER ECO	JR	AY	11/11/10

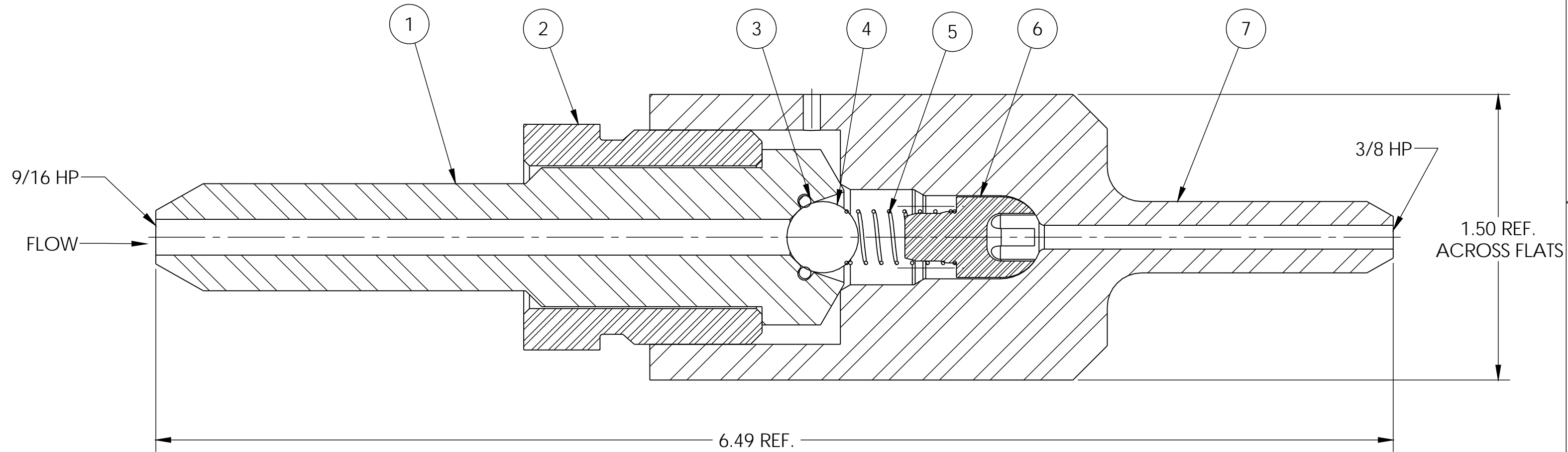

- NOTES:
1. LIGHTLY LUBRICATE ALL SCREW THREADS AND METAL TO METAL CONTACT SURFACES WITH FOOD GRADE "NEVER SEEZ" PTFE LUBRICANT.
  2. 130 FT-LB TORQUE REQUIRED FOR TIGHT SEAL.
  3. STAMP "MAWP 40KSI" AND FLOW DIRECTIONAL ARROW ON FLAT OF THE BODY.

DUPLICATION OR DISSEMINATION WITHOUT AUTHORIZATION PROHIBITED  
CONFIDENTIAL AND PROPRIETARY PROPERTY OF:  
 30 DSSIPEE RD.  
 P.O. BOX 9101  
 NEWTON, MA 02464-9101 USA  
ISN'T SCALE DRAWING TOLERANCES: = ±1/2"  $\frac{XX}{XX}$  = ± 1/32" DRAWN BY JBP  
 SCALE: 2:1 DATE: 9/24/07 .XX = ±.01 .XXX = ±.005 F. N. 802.00004PH  
**CHK VLV ASSY .56HP M PHARMA**  
 MATERIAL: VARIOUS SIZE: B DRAWING NUMBER: 802.00004PH REV: B